

NEXUS dosing

YOUR CHALLENGE. OUR MISSION.

The most efficient dosing systems on the market.

nexus-elastomer.com



dosing excellence

20+ years of know-how

1,000+ Nexus systems in use

Technology that inspires. People who make an impact.

At Nexus Elastomer Systems GmbH, you are at the center. Our solutions grow from true collaboration — driven by people who listen, understand and think ahead. With passion and technical excellence, we don't just develop precise dosing technology — we build partnerships that deliver.

With Nexus dosing systems, precision becomes measurable. Thanks to our patented SPLITNEX technology, you use your material with virtually no loss — less scrap, more yield. High energy efficiency protects resources and lowers costs. And because time matters, we analyze your processes right on the shop floor — identifying issues early and unlocking potential together.

Behind every solution are people — the Nexus x+ team. They are the heart of your success. For us, technology is never an end in itself — it's the result of real partnership. Our promise: innovation that exceeds expectations and inspires.

SERVOMIX

SPLITNEX

dosing



listening understanding

Your challenge. Our mission.

At Nexus, this isn't a slogan — it's your advantage: a binding promise. You're heard. Your situation is understood. Then we act — efficiently, solution-driven and reliably.

Your challenges today form the basis to create tomorrow's solutions together. The goal: implement your requirements precisely, noticeably optimize your processes and secure lasting results.

With know-how, innovative strength and genuine passion.



solution focused partnership

Your success. Our focus.

At Nexus, everything is aligned with you. Your goals and constraints set the pace — solutions arise in direct dialogue with you.

With a modular toolkit and a sure sense of balance between standard and custom, we develop dosing technology tailored to your needs. A high level of standardization guarantees reliability — and where individuality is needed, our creative minds create new solutions.

Efficient, precise and collaborative — for measurable results that move you forward.

Your success story begins here — with Nexus by your side.



Dietmar Waizenauer
Managing Partner und CBDO

« At Nexus Elastomer Systems, it's about partnership as equals: trust built not on words alone, but on tangible results and reliable support — starting together, growing together. »

future ready?

From vision to partnership-driven execution.

No application is the same — there's no cookie-cutter at Nexus. Standardize where it fits. Individualize where it counts.

Your success starts with an open dialog. Our NexPERTS listen, understand your requirements and turn them into tailored solutions that are efficient and cost-effective. The goal: to find the best dosing solution for you — and implement it together. Because real partnership means we move you forward. Step by step.



Mark Ostermann

Director of International Sales, Marketing and Service

« For us, partnership starts where expectations are surpassed and our solutions make a real difference for customers. »

let's make it happen



Why we consult differently.

Consulting

You get more than technical products: tailored consulting included. With process analysis, individual guidance and fit-for-purpose system solutions — precisely matched to your requirements.

Commitment

Reliability and accountability are the foundation of our consulting. Throughout the entire production cycle, you receive ongoing support — so your Total Cost of Ownership (TCO) is measurably optimized.

Efficiency

Through targeted questions and solid preparation, we save you time — already in the consulting phase. That lets you focus on what matters while we work on your solution in the background: efficient, structured and always with the goal of moving you noticeably forward.

Innovation instead of intuition.

Complex doesn't mean complicated!

For a long time, LSR injection molding was viewed as an intuitive process. Today, data, precision, efficiency and sustainability set the standard. With your feel for technology and our innovative solutions, that becomes your measurable competitive edge. Our systems combine technical finesse with straightforward operation — because real innovation shows in the clarity of the solution. We develop solutions that solve problems and simplify processes. Shape the future of the industry with us.

Become a technology leader. Jointly realized ideas put you where you belong: at the top.



dosing technology

Air-free material flow for almost no material waste.

Discover SPLITNEX by Nexus — the smart solution that automatically vents air bubbles from LSR material!

What this means for you:

Less waste, seamless workflows and consistently high quality — for your smoothest production yet.

- 100% air-free material flow
- Continuously stable processes
- Consistent product quality & perfect results
- More efficiency, less stress

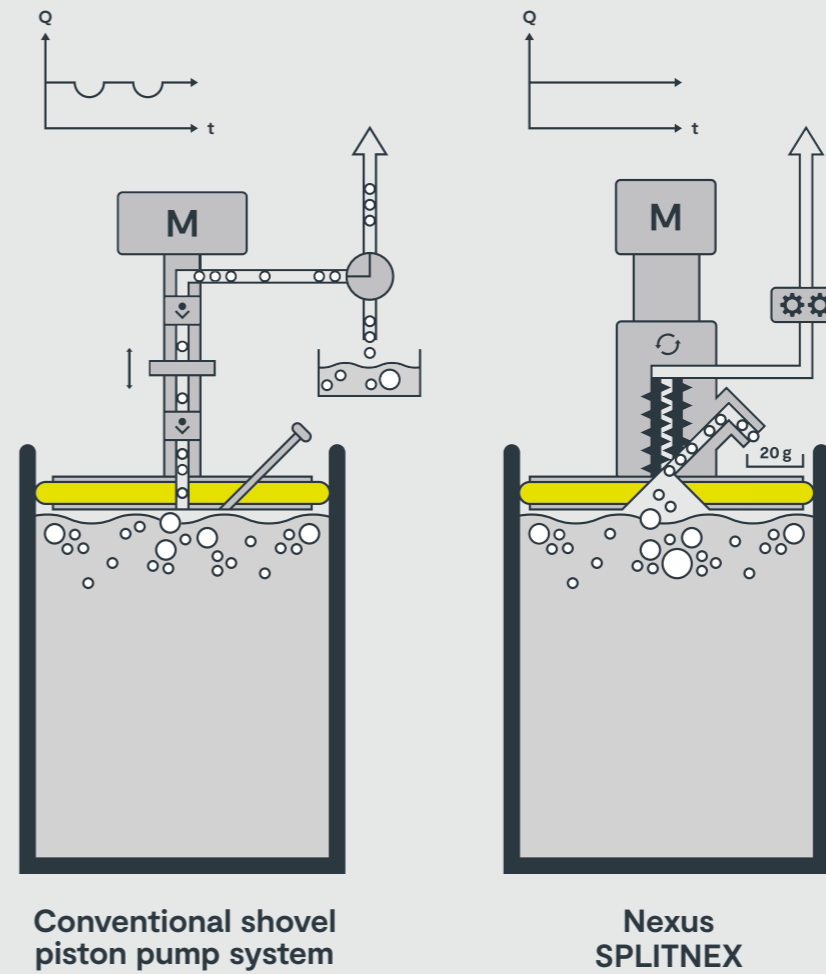

Save smart with Nexus SPLITNEX

EXAMPLE
 48 weeks production / year
 3 drum changes / week
 → 144 drum changes / year
 Material price: 12 € / kilo

Conventional shovel pump
 > 1.5% remaining quantity / drum change
 > 3 kg purging quantity / drum change

Nexus SPLITNEX
 < 0.3% remaining quantity / drum change
 40 g purging quantity / drum change

→ approx. 13,400 € material savings / year

Constant flow rate guarantees precise mix ratios

Nexus SPLITNEX

Less than 0.3% remaining quantity in the drum

Only 20 g flushing quantity at drum change

Total material savings of approx. 3–5%

Conventional shovel piston pump system

More than 2% remaining quantity in the drum

More than 1 kg purging quantity at drum change

Up to 30% cycle time reduction

Imagine how much more you can achieve when you can rely on a stable, dependable mix ratio. Nexus SPLITNEX provides exactly that confidence: precise mixes, consistently. That means cycle times reduced by up to 30%, greater flexibility, less stress and smoother production. We support you in optimizing your processes and reaching your goals faster — for your success and satisfaction.

Keep it simple: modular, compact, flexible.

When we say modular, we mean it: the Nexus MODULAR PROCESSING UNIT is impressive in its compactness and almost unlimited flexibility. It can be expanded almost indefinitely and is easy and quick to clean at the same time.

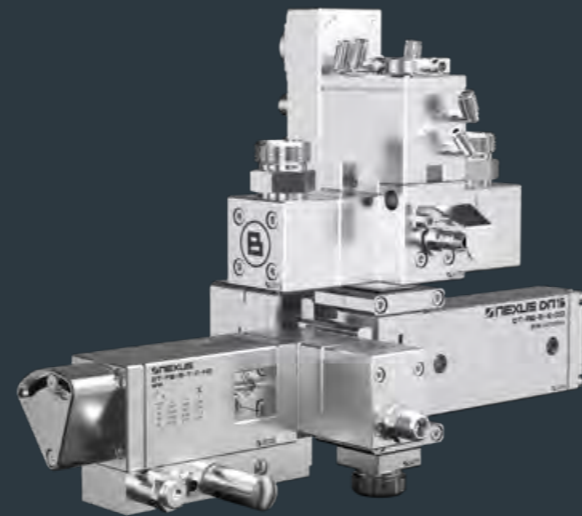

- Horizontal & vertical mixer
- Rapid color change
- Precise additives from 0.1% to 20%
- Modular design depending on the application
- Compatible with all Nexus metering systems

Maximum uptime

The MODULAR PROCESSING UNIT impresses with efficient maintenance thanks to reduced components. We guarantee unbeatable cleaning times for minimal downtime: 20 minutes without color. 50 minutes with color.

Maximum efficiency for your success: fast cleaning, less downtime — and more time for production!

Almost unlimited types and number of additives

Lowest tolerances allow additive addition in the nanoliter range:

- Color paste as well as flavor and aroma
- Hardness additives
- Adhesion-promoting additives
- Accelerating as well as retarding additives
- Heat-stabilizing additives

Nanoliter-level precision: maximum control for product quality and innovation!

It's a match.

Color & additive — precisely dosed.

To ensure consistent color quality and appearance, precise blending of colors and additives is essential. That's why we offer additive solutions that guarantee exact dosing, less scrap and outstanding results.

- Precise nanoliter technology
- Minimal waste of expensive additives
- Constant color dosage throughout the entire production
- Closed-loop system for continuous additive supply





Stop wasting material

Purge quantity + remaining volume
= < 0.5%

Purge quantity + remaining volume
= < 0.5%

Purge quantity + remaining quantity
= < 1%

Cartridge loading for smallest quantities
Booster for Nexus Central Feeding

Stop wasting energy

Up to 70% less energy consumption

Up to 70% less energy consumption

Up to 70% less energy consumption

Up to 70% less energy consumption

Stop wasting time

Quick-change system for shorter
cleaning time;
Drum change in less than 5 minutes

Quick-change system for shorter
cleaning time;
Drum change in less than 5 minutes

Quick-change system for shorter
cleaning time;
Pail change in less than 5 minutes

Quick-change system for shorter
cleaning time;
Cartridge change in less than 5 minutes

Drum types	200 / 20 L 55 gal. / 5 gal.	200 / 20 L 55 gal. / 5 gal.	20 L 5 gal.	Cartridges / Nexus Central Feeding
Standard Feeding Rate	1000 cm ³ / min	1000 cm ³ / min	1000 cm ³ / min	1000 cm ³ / min
Standard Feeding Pressure	170 bar / 2466 PSI	170 bar / 2466 PSI	170 bar / 2466 PSI	170 bar / 2466 PSI
Drum Change (angle)	Double-sided, quick and safe drum change from a 104° angle; Drum change within 5 minutes	Fast and safe drum change 90° angle on both sides; Drum exchange within 5 minutes	Pail change within 5 minutes	-

Try before buy

Test our LSR dosing systems
in your production for 90
days, risk-free.

If it doesn't meet your needs,
return it with no obligation.

Promise kept, trust earned!



Maximum Space Efficiency

The Nexus technology integrated into the ServoMix Z200 is designed for optimal space utilization. With a 104° drum loading angle, it fits seamlessly into the tightest production layouts.

Capable of handling both 200L and 20L kits, this machine offers unmatched versatility in the Nexus family.

Productivity Meets Precision

As the most flexible model in the Nexus ServoMix line, the ServoMix X200 delivers top-tier productivity and precision.

It supports both 200L and 20L kits, providing maximum flexibility at an attractive investment cost. Ergonomically designed loading systems further enhance efficiency, making your workflow smoother.

Compact Precision

The ServoMix X20 is the perfect choice for precision-driven production with 20L pale kits.

Its compact design, combined with Nexus' accuracy, makes it ideal for smaller shot volume applications.

Perfect for prototyping

The Nexus ServoMix X1 is built for unique applications, processing material from cartridge systems.

Perfect for testing, prototyping and specialized production, it also functions as a booster unit for central feeding systems.

Say goodbye to lengthy cleaning times.

With the Nexus SERVOMIX pump unit, cleaning is a breeze — in under 20 minutes the pump head is cleaned and ready for operation again. You gain valuable time, cut downtime and can focus on what truly matters: your company's success.

Trust in efficiency that moves you forward!

- User-friendly, with no “blind spots”
- Easy to clean
- A fraction of the mechanical components compared to plunger systems
- Long service life and extremely low maintenance



NexCare?

Service you can rely on!

Even the best systems in the world need care now and then. That's exactly when we're there for you — worldwide, fast and reliable.

Our service team supports you throughout your system's entire lifecycle — from commissioning to maintenance.

- Global support with short response times
- Spare parts always available — for maximum machine availability
- Knowledgeable experts whenever you need our support

”

Need support?

We're just a phone call away.

NexCare Service Hotline

+43 50 1215 300

support@nexus-elast.com

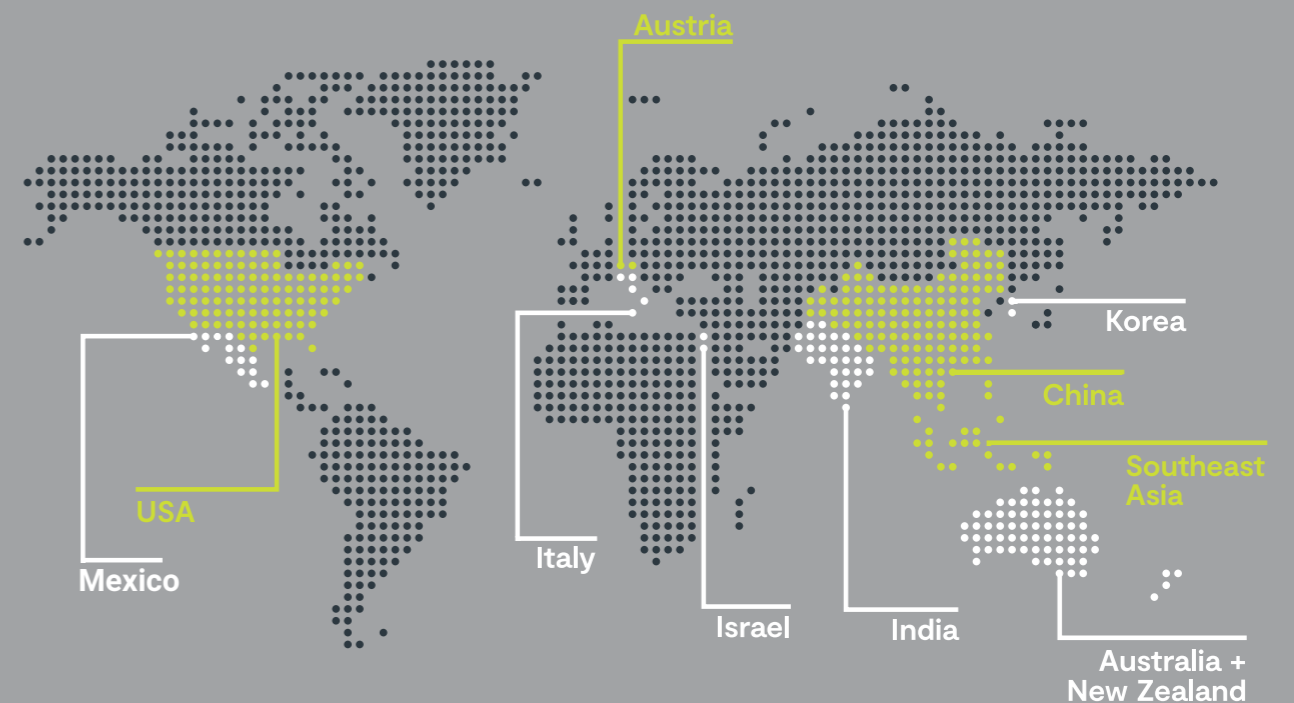

Pushing boundaries — solutions for unique challenges.

In today's manufacturing world, standard solutions hit their limits fast. Not for you — because you have the Nexus x+ team at your side.

Our system solutions are built to master even the most demanding production requirements with confidence. Whether continuous high-volume production, precise adjustment of material properties, or interruption-free processes, your future dosing technology is tuned for maximum efficiency and precision.

Uninterrupted production with the Tandem or Central Feeding System for centralized material supply, or ShoreMix for customized Shore-A hardnesses — we provide tailor-made solutions precisely aligned with your needs. Nexus stands for technology that thinks ahead — and moves you forward.



Verena Sophia Laucher
Marketing Manager

« With us, there's no marketing fluff — just real customer voices and success stories that show: the x+ team delivers on its promises. »

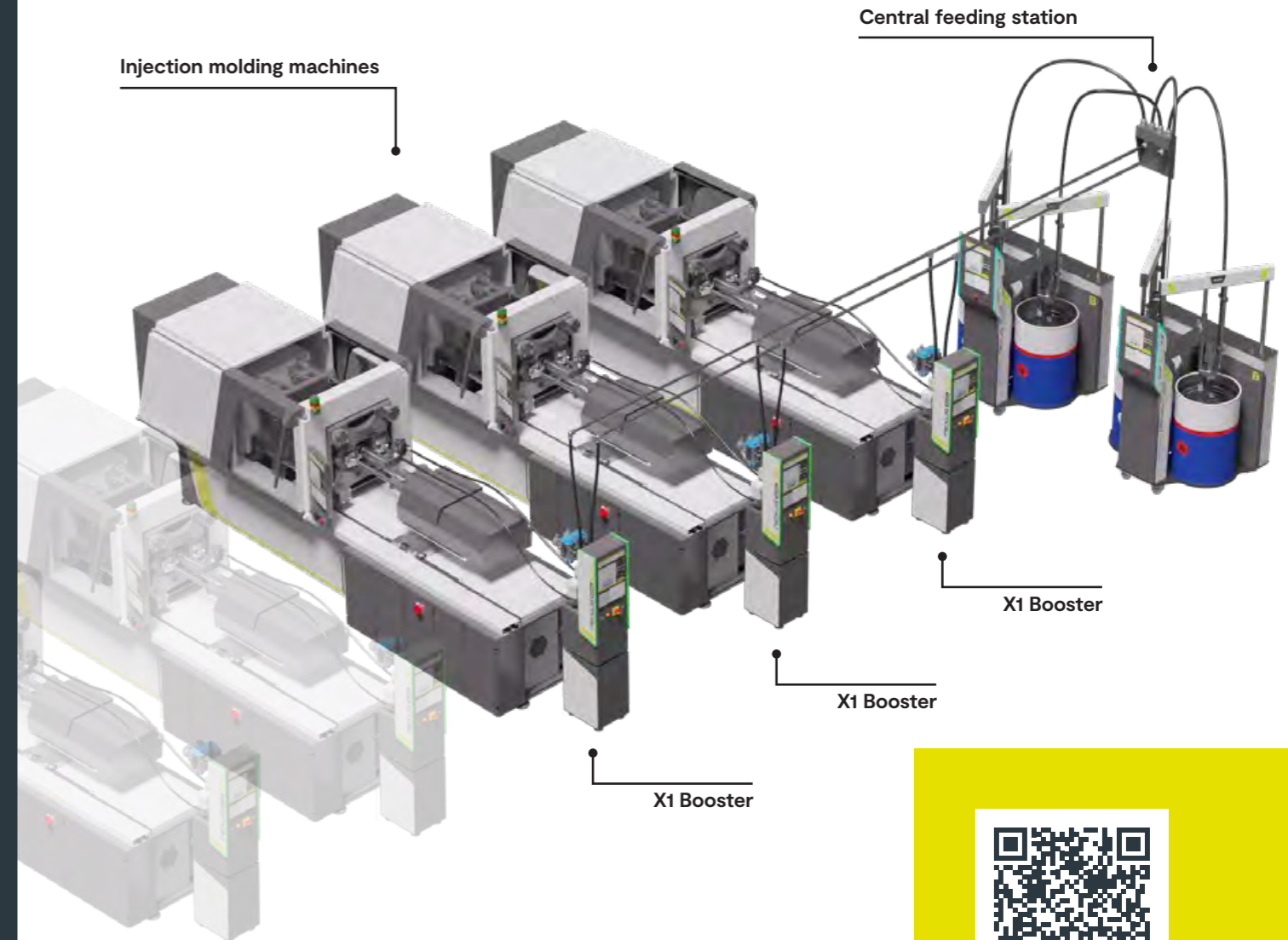

Central Feeding, the heart of your production.

Central Feeding optimizes material supply by centralizing the feed to injection molding machines. This boosts efficiency, reduces footprint and improves operator ergonomics. Ideal for cleanroom supply in medical device manufacturing.

Interested in more?

Get in touch.



Highlights of the Central Feeding System

Space-saving: get more from your floor space with a smaller footprint.

Efficient: continuous material feed optimizes production and increases throughput.

User-friendly: ergonomic operation and simplified material handling for operators.

22% cycle time reduction.

COMPANY

The American company Dymotek specializes in the production of 2-component liquid silicone components.

MACHINES

- Nexus Product: Servomix X200
- Machine: Arburg 570A
- Robot: Wittmann W832

INITIAL SITUATION

- 2K injection molding process
- Initial heating duration: 40 seconds
- Initial total cycle time: 60 seconds

PROJECT CHALLENGES

- Very complex production process
- Adhesion issues between thermoplast and liquid silicone

SOLUTIONS

- Integration of Nexus X200 dosing system
- Increased process window
- 22% reduction in cycle time
- Higher machine output achieved
- Consistent 1:1 mixing ratio with <0.2% variation



Dymotek success story
Find out more.



Manuel Lessl

Technical Support

« We show our customers what efficiency means: more output with less effort. We're proud to see them benefit from reduced cycle times and heating times. A true game changer in the production process. »

33% heating time reduction

Thanks to the reduction in heating time from 40 to just 27 seconds, our customer does not only save energy, but also significant costs. The result: faster production, lower expenses and greater flexibility to execute projects even more efficiently. The advantage: higher efficiency, lower costs and stronger competitiveness.

22% cycle time reduction

The total cycle time has been reduced from 60 to 47 seconds. This means an efficiency increase of 22%.

Ø 0.13% deviation

At a mixing ratio of 1:1, a deviation of 0.13% on average was observed after 100 cycles.

75,000h+ runtime.

COMPANY

Nolato GW Silicones is a leading manufacturer of silicone injection-molded components for the medical and automotive industries.

INITIAL SITUATION

- 58.2 cm³ shot weight components
- Drum change took too long

MACHINES

- Nexus Product: Servomix E200
- Machine: Engel eVictory 310/120

RESULT

- 450+ tons of processed material
- 1000+ barrel changes
- Reduced flushing quantity and minimal drum residue

158k \$ savings in 8 years with a single dosing system.



Nolato success story
Find out more.



David Haberfellner
Technical Sales Support

« A system that simply runs: less purging, less downtime, more parts per shift. With Nexus, you save costs across the entire lifecycle. »



450+ tons of processed material

Millions of parts have already been produced on GW Silicones' Servomix E200 — absolutely stress-free. Less worry, more assurance and smooth production — so our customer can focus on what matters.

75,000h+ without downtime

After more than 75,000 operating hours, the E200 still runs reliably and efficiently — with no technical issues. For our customer, that means less maintenance, less downtime and a stable production they can rely on.

Material change in <5min

Thanks to our efficient pallet system, drum changeovers are fast and seamless — in under 5 minutes. That saves valuable time, reduces downtime and keeps everything running smoothly — making our customer's operation even more productive.

nexus

dynamicx

Innovation for the future of material processing.

DynamicX stands for the consistent evolution of proven injection-molding technologies — specifically adapted to new fields of application. Our specialized solution elevates your material handling to a new level, beyond conventional industry standards.

DynamicX — because real innovation begins where standard solutions end.

NEXUS dynamicx

**PULSATION-FREE
AIR-FREE**



[Read more](#)

dynamicx

Take your processes to the next level.

Our DynamicX team develops custom solutions precisely tailored to your unique processes and products. The result: greater precision, higher quality and more efficient production that strengthens your competitiveness.



Mix and match.

Your application. Your combination. Your efficiency.

We will work together with you to identify the right applications and combinations to maximize the performance of your process.

With the DynamicX team, you have an innovative partner by your side.

Coating

Coatings on different substrates and roll-to-roll processes.

Benefit from precise, consistent coating while staying fully flexible in your processes.

Tire inner-liner coatings

Tire inner-liner coating for noise reduction, sealing or self-healing.

Benefit from high production speed, stable quality and flexibility in manufacturing.

Wire coatings

Extrusion process for coating wires with liquid silicone.

Create a seamless, durable and flexible protective layer for wires with us.

Direct inject

Continuous filling of insulators and other large-volume components with liquid elastomers.

With Nexus DynamicX, direct injection of large-volume components becomes effortless.

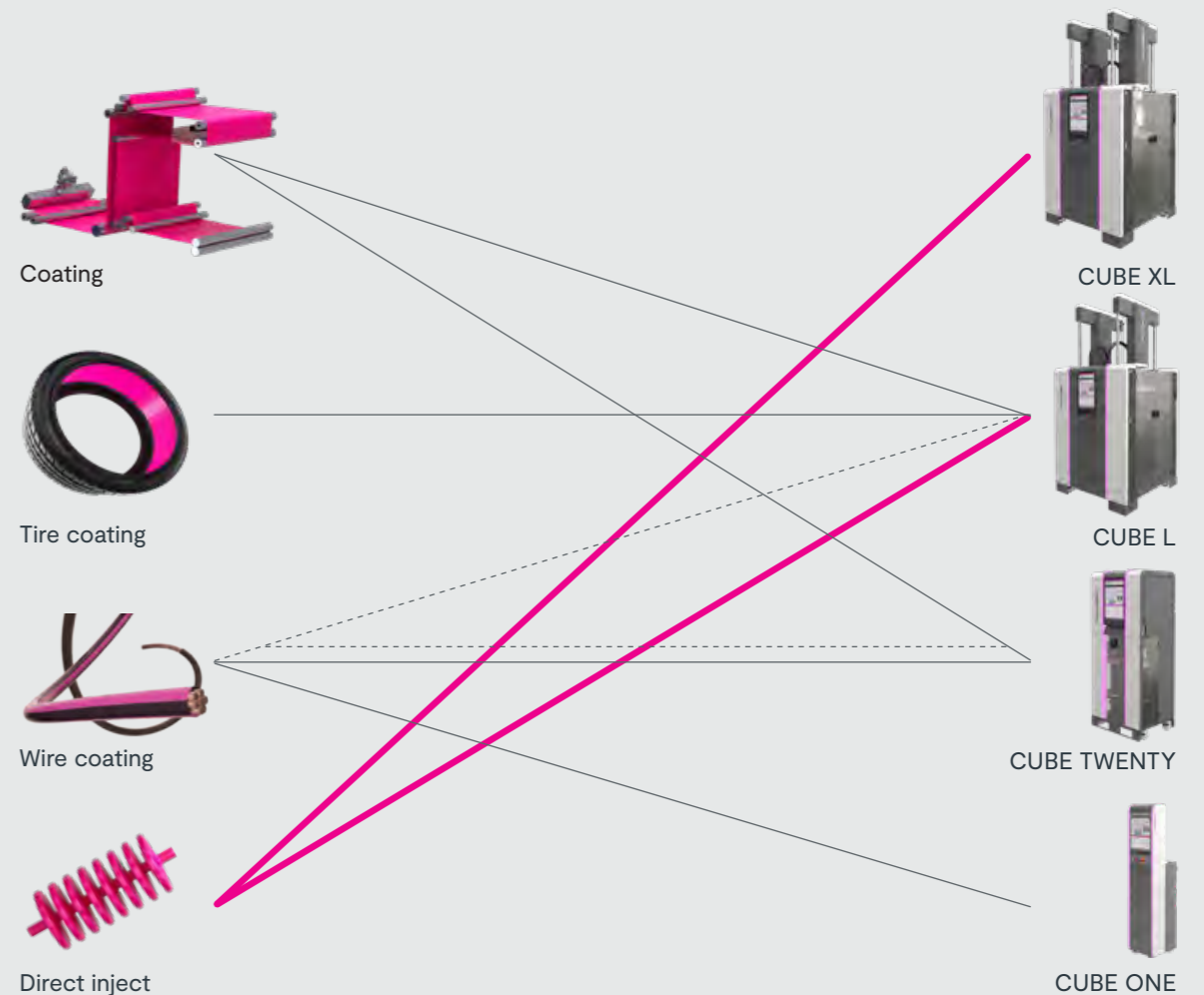

Tomorrow's technology. Today.

Progress in every step.



PULSATION FREE



DYNAMIC PROCESS



AIR FREE



FULL PROCESS CONTROL



HIGH FLOW



SERVODRIVEN

Our DynamicX team unlocks the full potential of your production and takes your processes to the next level. DynamicX sets new standards: a single technology platform – countless possibilities. It creates entirely new possibilities for your manufacturing, propels your processes into the future and gives you the competitive edge that makes the difference.

DynamicX – True innovation starts beyond the standard.



let's get it started

Your trusted partner for successful projects.

Your search is over. You've found a partner you can trust. The x+ team stands by your side — from the first idea through development and implementation to series production.

We work with you as equals — transparent, solution-oriented and committed. Our aim is not just to deliver technology, but to live true partnership.

Let's achieve your goals together — with trust, consulting and a team that keeps its promises.



”

Andreas Wurm

Chief Operating Officer (COO)

« We are more than a supplier — we're your sparring partner from idea to series production. Trust, transparency and real solutions come first with us. »

AUSTRIA

Nexus Elastomer Systems GmbH
Solarstraße 5, 4653 Eberstalzell

USA

Nexus Elastomer Systems Inc.
1 South Wacker Drive, Suite 3250,
Chicago, IL 60606